

# EA448

## *Generator Automatic Voltage Regulator Operation Manual*



Permanent Magnet Generator or A.R.E.P or Auxiliary Winding Type  
Compatible with Leroy Somer R448\*

\* Use for reference purpose only and not a genuine Leroy Somer product.



This component must be housed inside alternator terminal box and be fitted by a competent electrical engineer.

---

SP POWERWORLD LTD  
Willows, Waterside, Ryhall, Stamford, Lincs, PE9 4EY, UK  
Tel: +44 1780 756872 - Email: [info@sp-powerworld.com](mailto:info@sp-powerworld.com)  
[www.sp-powerworld.com](http://www.sp-powerworld.com)

---

## 1. INTRODUCTION

### Sensing Input

Terminal	0 ~ 110V = 95 ~ 140V
	0 ~ 220V = 170 ~ 260V
	0 ~ 380V = 340 ~ 520V
Frequency	50 / 60 Hz, selectable

### Power Input

Voltage	40 ~ 150 VAC, 3 phase
---------	-----------------------

### Voltage Output

Max 160VDC @ 120VAC

### Current Output

Max 10 A

### Voltage Regulation

<  $\pm 0.5\%$  ( with 4% engine governing )

### Voltage Build-up

Residual voltage at AVR terminal > 5 VAC

### External Volts Adjustment

$\pm 10\%$  @ 1K ohm

### Response Time

0.3 ~ 1sec @  $\pm 20\%$  Voltage Vibration

### Current Droop

2 sec. Max 4% @ P.F. = 0.8

### Auxiliary Winding

6~150VAC (No load rms)

### LAM Voltage Drop Rate

10% and 15% selectable

### Dimensions

203mm L \* 153mm W \* 60.5mm H

### Weight

970g  $\pm 2\%$

## 2. OPERATION PROCEDURE

### 2.1 Jumper Adjustment

1. ST1 : Connected wire ST1 for Single phase measurement. Cut wire ST1 for three phase measurement.
2. ST2 : Response Time : Fast(disconnected) / Slow(Connected) Select.  
PS : It should do stable adjustment with P3.
3. ST3 : For 50/60HZ selection use Jumper.ST3.
4. ST4 : Remove wire ST4 to Connect external potentiometer (1K $\Omega$ ). Connect wire ST4 when it is not necessary to connect external potentiometer.
5. ST6 : Instantaneous Compensation for Voltage.  
PS: Remove wire ST6 when the regulator is used in higher 600KVA.
6. ST7 : Jumpers connected.
7. J1 : Connected with LAM protection. Discounted without LAM protection. No LAM protection, for knee frequency adjustment use P4.
8. J2 : LAM Voltage DROP RATE, 1-2 about 12%, 2-3 about 20%.

### 2.2 Adjustment

1. P1 : Adjustment of quadrature droop. (MAX 12%).
2. P2 : Output Voltage adjustment by using P2.

3. P3 : Stability.

4. P4 : Under-speed (U/F) and LAM protection: for knee frequency adjustable us P4.

5. P5 : Excitation over current adjustment use P5 : 3.5A ~ 10A.

### 2.3 Wiring

1. X1-X2 : Excitation power auxiliary winding input, single phase 2 wires.
2. Z1-Z2 : Harmonic Power input (Multi-Harmonic).
3. E+ : Positive Output Terminal for Excitation power.
4. E- : Negative Output Terminal for Excitation power.
5. 0 ~ 110 : Measure Power Input 110VAC.
6. 0 ~ 220 : Measure Power Input 220VAC.
7. 0 ~ 380 : Measure Power Input 380VAC.

### Note :

1. When excitation power is three phase input, connect X2, X1, Z2. See Figure 3.
2. Fuse capacity : 10A / 250V.
3. When the regulator works normal, the LED will keep "Light" condition. The LED will be turned off when Stand-by power works in normal usual. In this condition, the rated voltage will decrease automatically and the voltage adjustment will failure.

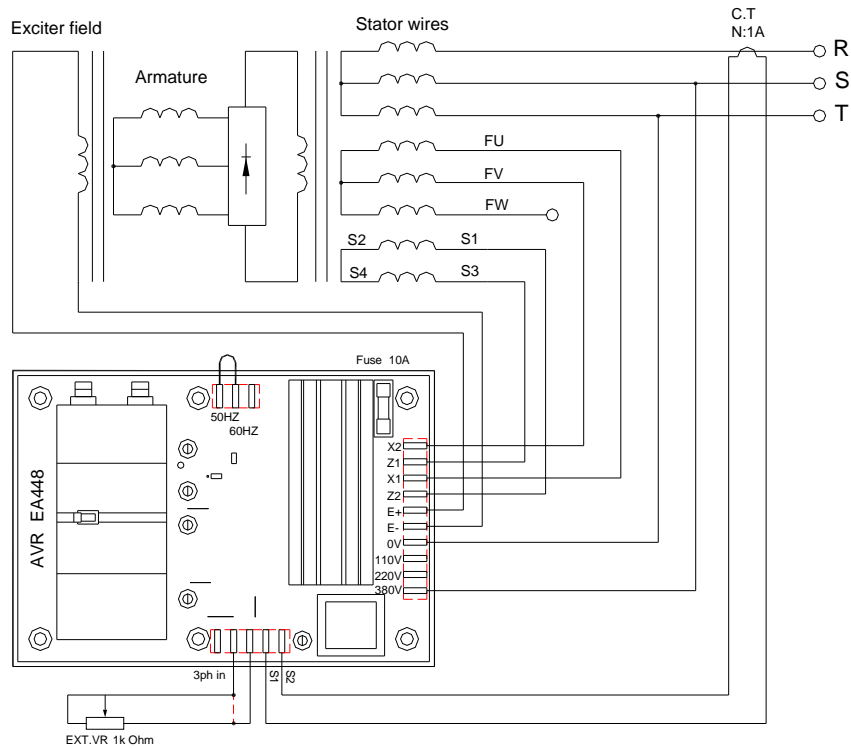

Figure 1 Power and Wiring for Harmonic Power

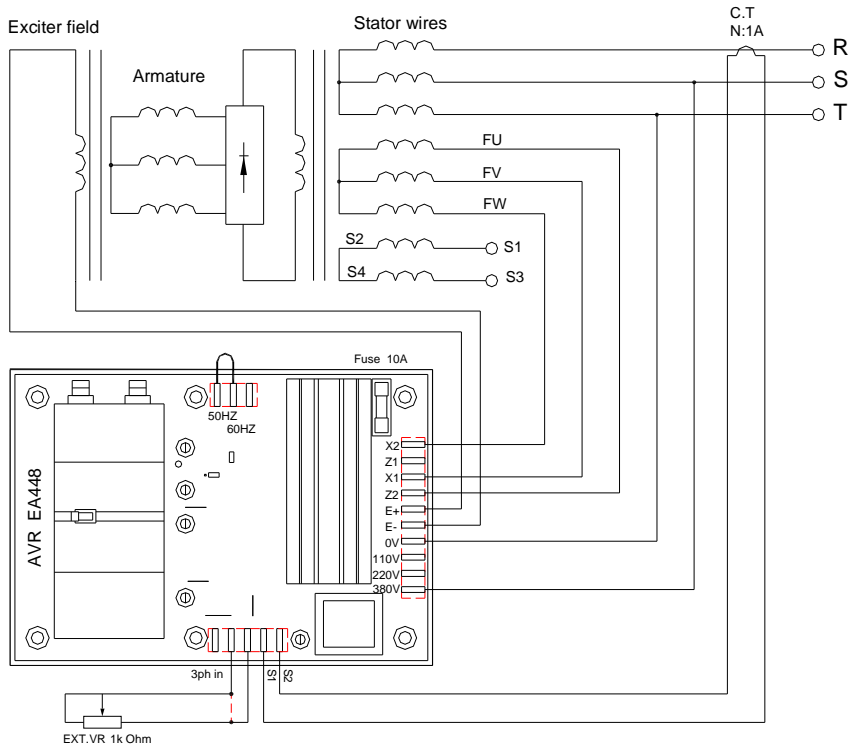

Figure 2 Three phase wiring

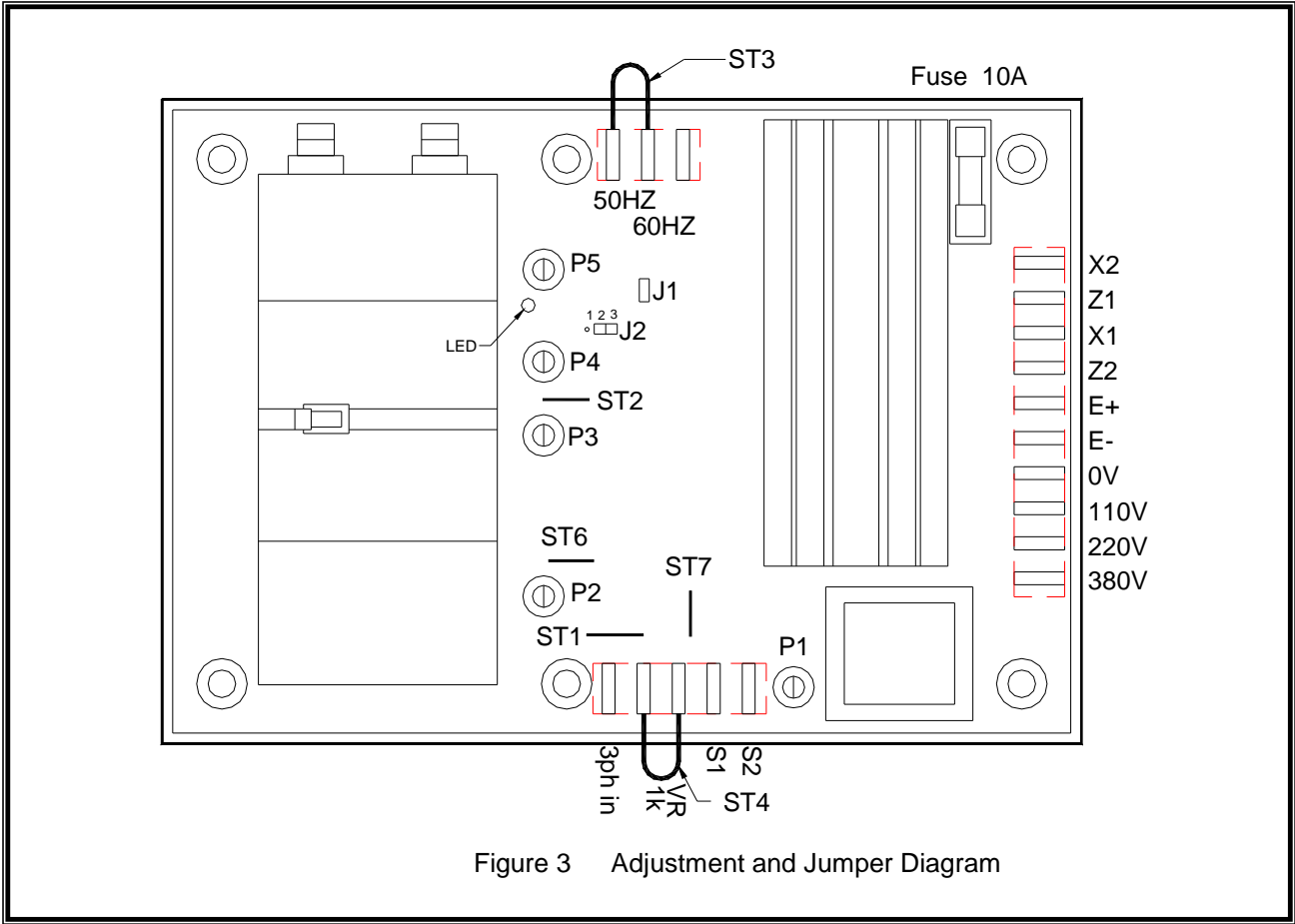

Figure 3 Adjustment and Jumper Diagram

P.S. Please use the fuse of the original plant.