

EA321

Generator Automatic Voltage Regulator Operation Manual

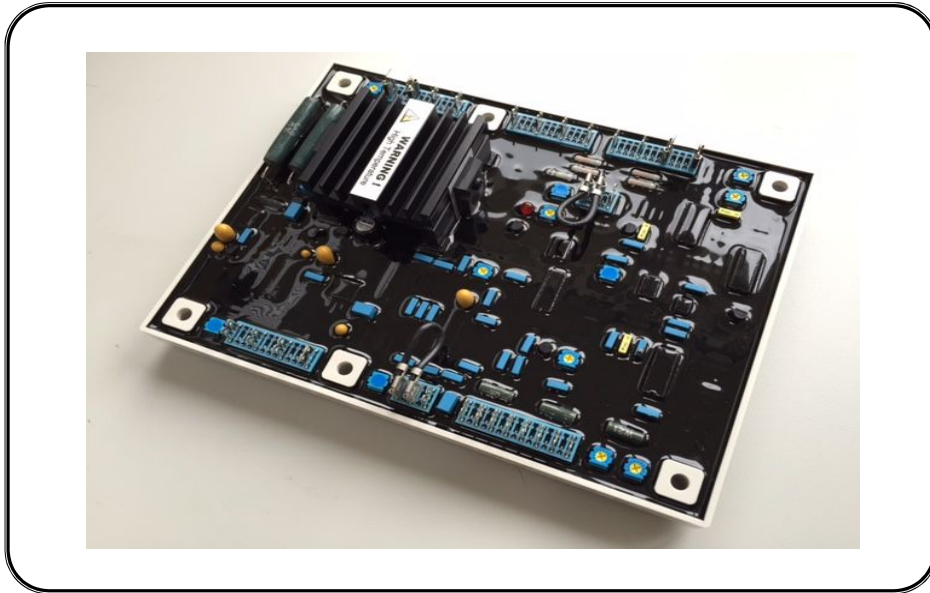

Self Excited Automatic Voltage Regulator. Compatible with the Newage Stamford MX321 - MX321-2 - E000-23212 - Onan 305-0823.



This component must be housed inside alternator terminal box and be fitted by a competent electrical engineer.

SP POWERWORLD LTD
Willows, Waterside, Ryhall, Stamford, Lincs, PE9 4EY, UK
Tel: +44 1780 756872 - Email: info@sp-powerworld.com
www.sp-powerworld.com

1. INTRODUCTION

Sensing Input

Voltage 190 ~ 264 VAC Max, 2 or 3 phase
Frequency 50 / 60 Hz, nominal

Power Input (PMG)

Voltage 170 ~ 220 VAC Max, 3 phase 3 wire
Current 3A phase
Frequency 100 ~ 120 Hz, nominal

Output

Voltage Max. 120 VDC
Current Continuous 3.7A
Intermittent 6A for 10 sec
Resistance Min. 15 ohm

Voltage Regulation

< $\pm 0.5\%$ (with 4% engine governing)

Voltage Build-up

Residual voltage at AVR terminal > 5 VAC

Thermal Drift

0.02% per °C change in AVR ambient

External Volts Adjustment

$\pm 10\%$ with 5K ohm 1 watt trimmer

Unit Power Dissipation

Max. 18 watt

Under Frequency Protection (Factory Setting)

Set point 95% Hz
Slope 100 ~ 300% down to 30 Hz

Current Limit Input

10 ohms burden
Sensitivity range 0.5 ~ 1A

Soft Start Ramp Time

0.4 ~ 4 sec.

Analogue Input

Max. Input ± 5 VDC
Sensitivity 1V for 5% generator volts
Input Resistance 1K ohm

Quadrature Droop Input

Burden 10 ohm
Max. sensitivity 0.22 A for 5% droop (PF=0)
Max. input 0.33 A

Over Voltage Detector Input

Set point 300V. Time delay 1 Sec (fixed)
CB trip coil volts 10 ~ 30 VDC
CB trip coil resistance 20 ~ 60 ohms

Over Excitation Protection

Set point 75 VDC
Time delay 8 ~ 15 sec (fixed)

Typical System Response

AVR response 10 ms
Filed current to 90% 80 ms
Machine Volts to 97% 300 ms

Environmental

100Hz ~ 2kHz 3.3g
Operating temperature -40 to +70 °C
Relative Humidity 0 ~ 70 °C 95% (see note 7)
Storage temperature -55 to +80 °C

Dimensions

203mm L * 153mm W * 39.1mm H

Weight

530g $\pm 2\%$

2. GENERAL DESCRIPTION

- EA321 is a two phase sensed Automatic Voltage Regulator and forms part of the excitation system for a brush-less generator. Excitation power is derived from a three-phase permanent magnet generator (PMG), to isolate the AVR control circuits from the effects of nonlinear loads and to reduce radio frequency interference on the generator terminals. Sustained generator short circuit current is another feature of the PMG system.
- The AVR senses the voltage in the main generator winding and controls the power fed to the exciter stator and hence the main rotor to maintain the generator output voltage within the specified limits, compensating for load, speed, temperature and power factor of the generator.
- Soft start circuitry is included to provide a smooth controlled build up of generator output voltage.

- A frequency measuring circuit continually monitors the shaft speed of the generator and provides under-speed protection of the excitation system by reducing the generator output voltage proportionally with speed below a pre-settable threshold. A further enhancement of this feature is an adjustable volts per Hertz slope to improve engine recovery time on turbo charged engines. Soft start circuitry is included to provide a smooth controlled build up of generator output voltage.
- Uncontrolled excitation is limited to a safe period by internal shutdown of the AVR output device. This condition remains latched until the generator has stopped.
- Provision is made for the connection of a remote voltage trimmer, allowing the user fine control of the generator's output.
- An analogue input is provided allowing connection to a controller or other external devices with compatible output.

- The AVR has the facility for droop CT connection, to allow parallel running with other similarly equipped generators.

NOTE :

1. Derate linearly from 3.7A at 50 °C to 2.7A at 70 °C.
2. The stated voltage regulation may not be maintained in the presence of certain transmitted radio signals. Any change in regulation will fall within the limits in Criteria B of S.EN.61000-6-2 : 2001.
3. After 10 minutes.
4. Applies to Mod status E onwards. Generator de-rate may apply. Check with factory. Factory set, semi-sealed, jumper selectable.
5. Any device connected to the analogue input must be fully looting (galvanically isolated from ground), with an insulation strength of 500V ac.
6. Non condensing.

3. SUMMARY OF AVR CONTROLS

CONTROL	FUNCTION	DIRECTION
VOLTS	To adjust generator output voltage	Clockwise increases output voltage
STABILITY	To prevent voltage hunting	Clockwise increase the damping effect
UFRO	To set the UFRO knee point	Clockwise reduces the knee point frequency
DROOP	To set the generator droop to 5% at 0pf	Clockwise increases the droop
TRIM	To optimize analogue input sensitivity	Clockwise increases the gain or sensitivity
EXC	To set the over excitation cut off level	Clockwise increase the cut off level
DIP	To set the frequency related voltage dip	Clockwise increases the voltage dip
DWELL	To set the HZ related recovery time	Clockwise increases the recovery time
I LIMIT	To set the stator current limit	Clockwise increases the current limit
OVER V	To set the over voltage trip level	Clockwise increases the trip level
RAMP	To set the no load voltage RAMP up time	Clockwise increases the voltage ramp time
RMS	To set 3 phase RMS detected	

4. ADJUSTMENT OF AVR CONTROLS

4.1 Voltage Adjustment

The generator output voltage is set at the factory, but can be altered by careful adjustment of the VOLTS control on the AVR board, or by the external hand trimmer if fitted.

Terminals 1 and 2 on the AVR will be fitted with a shorting link if no hand trimmer is required.

WARNING

Do not increase the voltage above the rated generator voltage. If in doubt, refer to the rating plate mounted on the generator case.

Do not ground any of the hand trimmer terminals, as these could be above earth potential. Failure to observe this could cause equipment damage.

If a replacement AVR has been fitted or re-setting of the VOLTS adjustment is required, proceed as follows :

1. Before running generator, turn the VOLTS control fully anti-clockwise.
2. Turn remote volts trimmer (if fitted) to midway position.
3. Turn STABILITY control to midway position.
4. Connect a suitable voltmeter (0~300V ac) across line to neutral of the generator.
5. Start generator set, and run on no load at nominal frequency e.g. 50~53Hz or 60~63Hz.
6. If the red Light Emitting Diode (LED) is illuminated, refer to the Under Frequency Roll Off (UFRO) adjustment..
7. Carefully turn VOLTS control clockwise until rated voltage is reached.
8. If instability is present at rated voltage, refer to stability adjustment, then re-adjust voltage if necessary.
9. Voltage adjustment is now completed.

4.2 Stability Adjustment

- The AVR includes stability or damping circuit to provide good steady state and transient performance of the generator.
- A jumper link selector is provided to optimize the response of the stability circuit to various size generators.
- The link should be positioned as shown in the diagram according to the KW rating of the generator. The correct setting of the Stability adjustment can be found by running the generator at no load and slowly turning the stability control anti-clockwise until the generator voltage starts to become unstable. The optimum or critically damped position is slightly clockwise from this point (i.e. where the machine volts are stable but close to the unstable region).

4.3 Under Frequency Roll Off (UFRO) Adjustment

The AVR incorporates an under-speed protection circuit which gives a volts/Hz characteristic when the generator speed falls below a presentable threshold known as the “knee” point. The red Light Emitting Diode (LED) gives indication that the UFRO circuit is operating.

The UFRO adjustment is preset and sealed and only requires the selection of 50 or 60Hz and 4 pole or 6 pole, using the jumper link as shown in the

diagram. For optimum setting, the LED should illuminate as the frequency falls just below nominal, i.e. 47Hz on a 50Hz system or 57Hz on a 60Hz system.

4.4 DROOP Adjustment

Generators intended for parallel operation are fitted with a quadrature droop C.T. which provides a power factor dependent signal for the AVR. The C.T. is connected to S1, S2 on the AVR, (see generator wiring diagram for details). The DROOP adjustment is normally preset in the works to give 5% voltage droop at full load zero power factors. Clockwise increases the amount of C.T. signal injected into the AVR and increases the droop with lagging power factor (cos Ø). With the control fully anti-clockwise there is no droop.

4.5 Trim Adjustment

- An analogue input (A1 A2) is provided to connect to the controller or other devices. It is designed to accept dc signals up to ±5 volts.
- The dc signal applied to this input adds to the AVR sensing circuit. A1 is connected to the AVR 0 volts. Positive on A2 increases excitation. Negative on A2 decreases excitation.
- The TRIM control allows the user to adjust the sensitivity of the input. With TRIM fully anti-clockwise the externally applied signal has no effect. Clockwise it has maximum effect.
- Normal setting is fully clockwise when used with a controller.

WARNING

Any devices connected to this input must be fully floating and galvanically isolated from ground, with an insulation capability of 500V ac. Failure to observe this could result in equipment damage.

4.6 Er Excitation (EXC) Adjustment

This adjustment is set and sealed in the works and should not be tampered with. An over excitation condition is indicated by the illumination of the red LED which also indicates under-speed running and over-volts.

The generator must be stopped to reset an over-excitation trip.

4.7 DIP Adjustment

This feature is mostly used when the generator is coupled to turbo charged engines with limited block load acceptance. The feature works by increasing the V/Hz slope to give greater voltage roll off in proportion to speed.

With the DIP control fully anti-clockwise, the generator voltage will follow the normal V/Hz line as the speed falls below nominal. Turning the DIP control clockwise provides greater voltage roll off aiding engine recovery.

4.8 DWELL

This feature is mostly used when the generator is coupled to turbo charged engines with limited block load acceptance. The feature works by introducing a delay between speed recovery and voltage recovery and allows a greater DIP setting without instability.

With the DWELL control fully anti-clockwise, the generator voltage will follow the V/Hz line. Turning the DWELL control clockwise increase the delay time between speed recovery and voltage recovery.

4.9 Current Limit (I LIMIT) Adjustment

This feature is mostly used to limit short circuit current or to provide a current limit on motor starting. To use this feature, current limit CT's of the correct ratio need to be connected to the AVR S1 S2 terminals. There is an internal time limit of 10 seconds. Consult the factory before using this feature.

4.10 OVER VOLTAGE (OVER V) ADJUSTMENT

This adjustment is set and sealed in the works and should not be tampered with. An over voltage condition is indicated by the illumination of the red LED which also indicates under-speed running and over-excitation. The generator must be stopped to reset an over-voltage trip.

4.11 RAMP

The AVR includes a soft start or voltage ramp-up circuit to control the rate of voltage build up, when the generator runs up to speed. This is normally pre-set and sealed to give a voltage ramp-up time of approximately 3 seconds. If required, this can be adjusted between the limits defined in the specification.

5. FITTING AND OPERATING (Refer to generator wiring diagram for connection details)

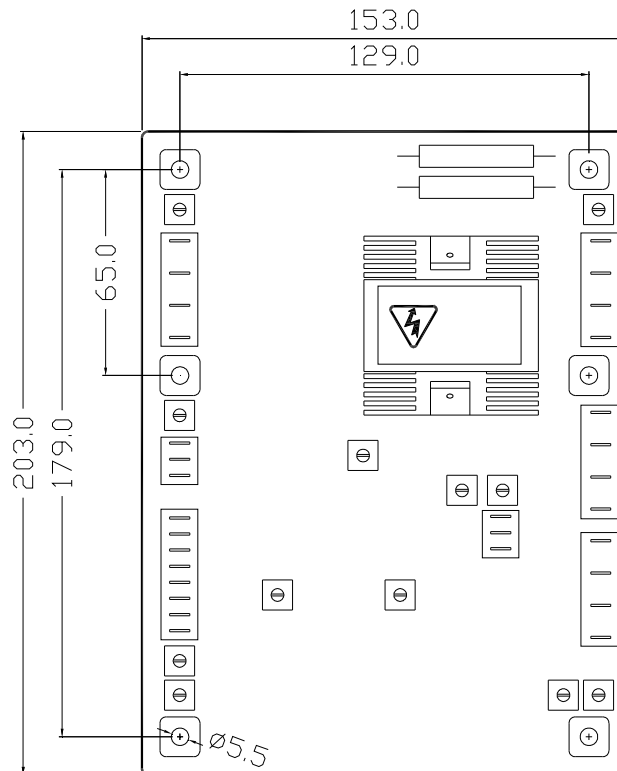

Outline Drawing
Figure 1

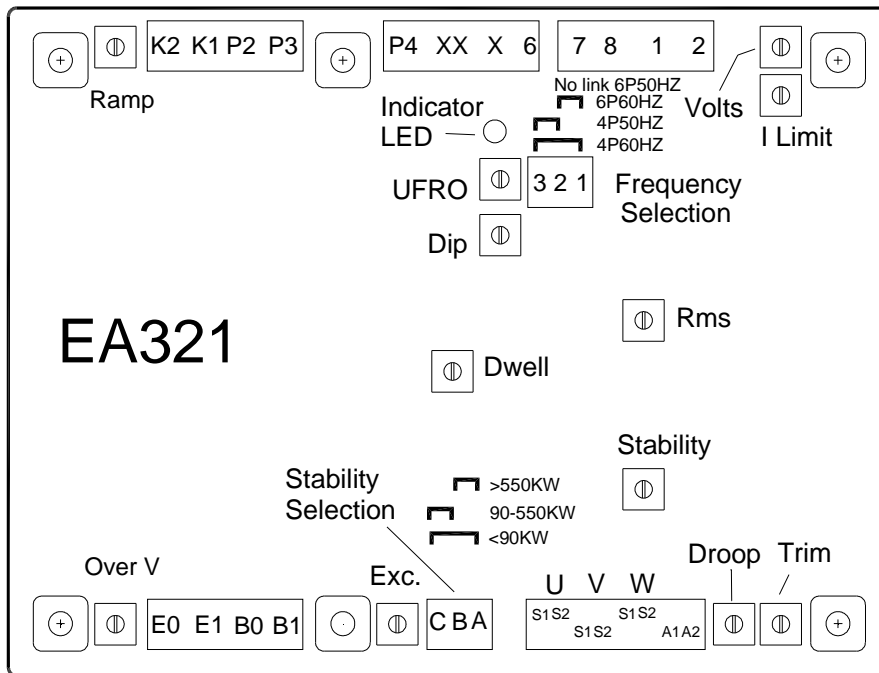

Figure 2 Jisposition Drawing

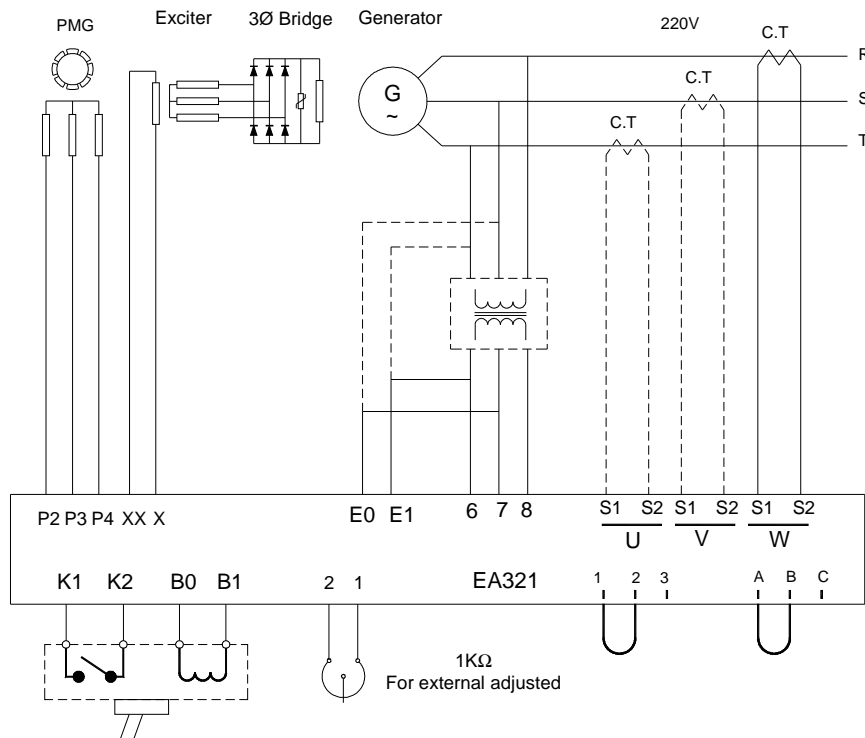

Figure 3 Wiring Drawing

Note : When the system voltage over 220VAC, a transformer is necessary at sensing input terminal is recommend.

※ If the step above can't make the charger working still please contact with us.