

# ADVR-440

## **Generator Automatic Voltage Regulator Operation Manual**

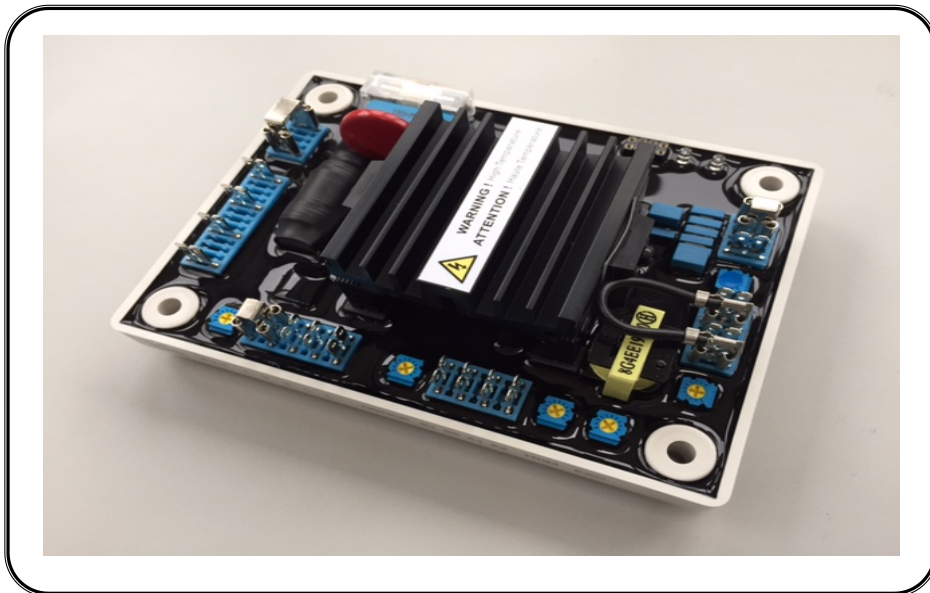

Analog / Digital, Single-phase detection - Excitation Current 4 Amps.  
For use in brushless, self-excited (shunt) generators.  
Compatible with Stamford AS440 E000-24403\* AVR

\* All manufacturer names and numbers are used for reference purpose only  
and do not imply that any part is the product of these manufacturer.



SP POWERWORLD LTD  
Willows - Waterside - Ryhall - Stamford - Lincs - PE9 4EY - United Kingdom  
Tel: +44 (0)115 923 2568 - Email: [info@sp-powerworld.com](mailto:info@sp-powerworld.com)  
Web: [www.sp-powerworld.com](http://www.sp-powerworld.com)

ISO 9001  
ETC

---

## SECTION 1 : SPECIFICATION

### Sensing Input (7, 8) Average Reading

Voltage 110 / 220 Vac, 1 phase 2 wire  
Jumper setting  
90 – 130 Vac @ 110 Vac  
180 – 260 Vac @ 220 Vac  
Frequency 50/60 Hz (Jumper setting)

### Power Input (7, Z2)

Voltage 40 – 300 Vac, 1 phase 2 wire  
Frequency 40 – 60 Hz

### Excitation Output (F1, F2)

110V 1 phase Continuous 33 Vdc 4A  
Max. 45 Vdc 7.5A for 10 secs.  
220V 1 phase Continuous 63 Vdc 4A  
Max. 90 Vdc 7.5A for 10 secs.  
Resistance Min. 15 ohms, Max.100 ohms  
Fuse Spec. Slow blow 5 x 20mm S505-6.3A

### External Voltage Adjustment (1, 2)

Max.+/- 10% @ 1 K ohm 1 watt potentiometer

### Voltage Regulation

Less than +/- 0.5% (with 4% engine governing)

### Build Up Voltage

5 Vac 25 Hz residual volts at power input terminal

### Soft Start Ramp Time

4 seconds +/- 10%

### Typical System Response

Less than 20 milliseconds

### EMI Suppression

Internal electromagnetic interference filtering

### Static Power Dissipation

Max. 4 watts

### Quadrature Droop Input (S1, S2)

Burden Less than 0.1 ohm  
Max. sensitivity 0.07A for 5% droop (PF=0)  
Droop adjustable  
Max. input 0.33A

### Analogue Voltage Input (A1, A2)

Input resistance More than 2K ohm  
Max. input +/- 5 Vdc or +10 Vdc  
Sensitivity 1Vdc for 5% Generator Volts  
TRIM adjustable

### Under Frequency Protection (Factory Presets)

50 Hz system knee point at 45 Hz  
60 Hz system knee point at 55 Hz

### Over Excitation Protection

Set point 40 – 110 Vdc @ power input 220 Vac  
EXT. adjustable  
Set point 110 Vdc +/- 10% @ power input 220 Vac  
(Factory Presets)  
The output will drop after a 10 seconds delay

### Voltage Thermal Drift

Less than 3% at temperature range -40 to +70 °C

### Under Frequency Knee Point Thermal Drift

Less than +/- 0.1 Hz at -40 to +70 °C

### Environment

Operating Temperature -40 to +70 °C  
Storage Temperature -40 to +85 °C  
Relative Humidity Max. 95%  
Vibration 5.5 Gs @ 60 Hz

### Dimensions

135.0 (L) x 100.0 (W) x 45.0 (H) mm  
5.31 (L) x 3.94 (W) x 1.77 (H) inch

### Weight

405 g +/- 2%  
0.89 lb +/- 2%

## SECTION 2 : APPEARANCE / DIMENSIONS / INSTALLATION DRAWING

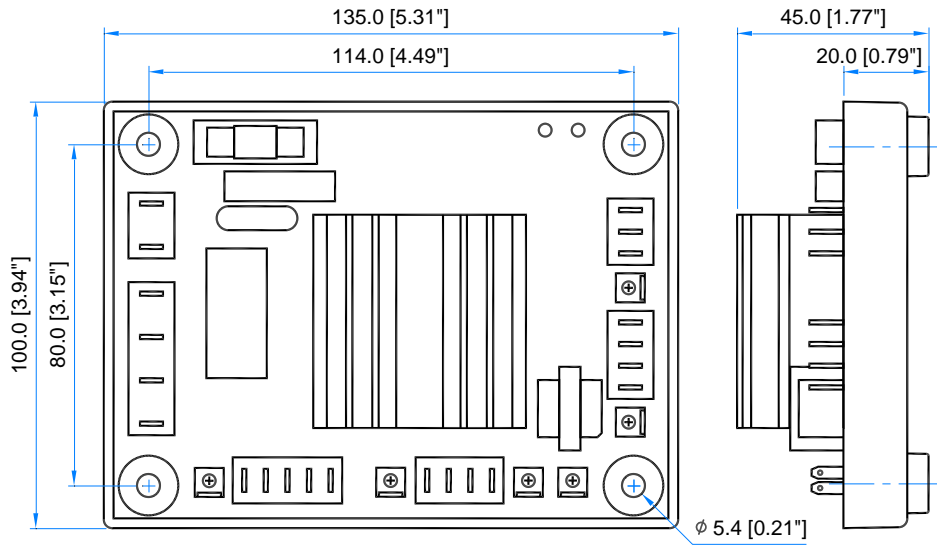
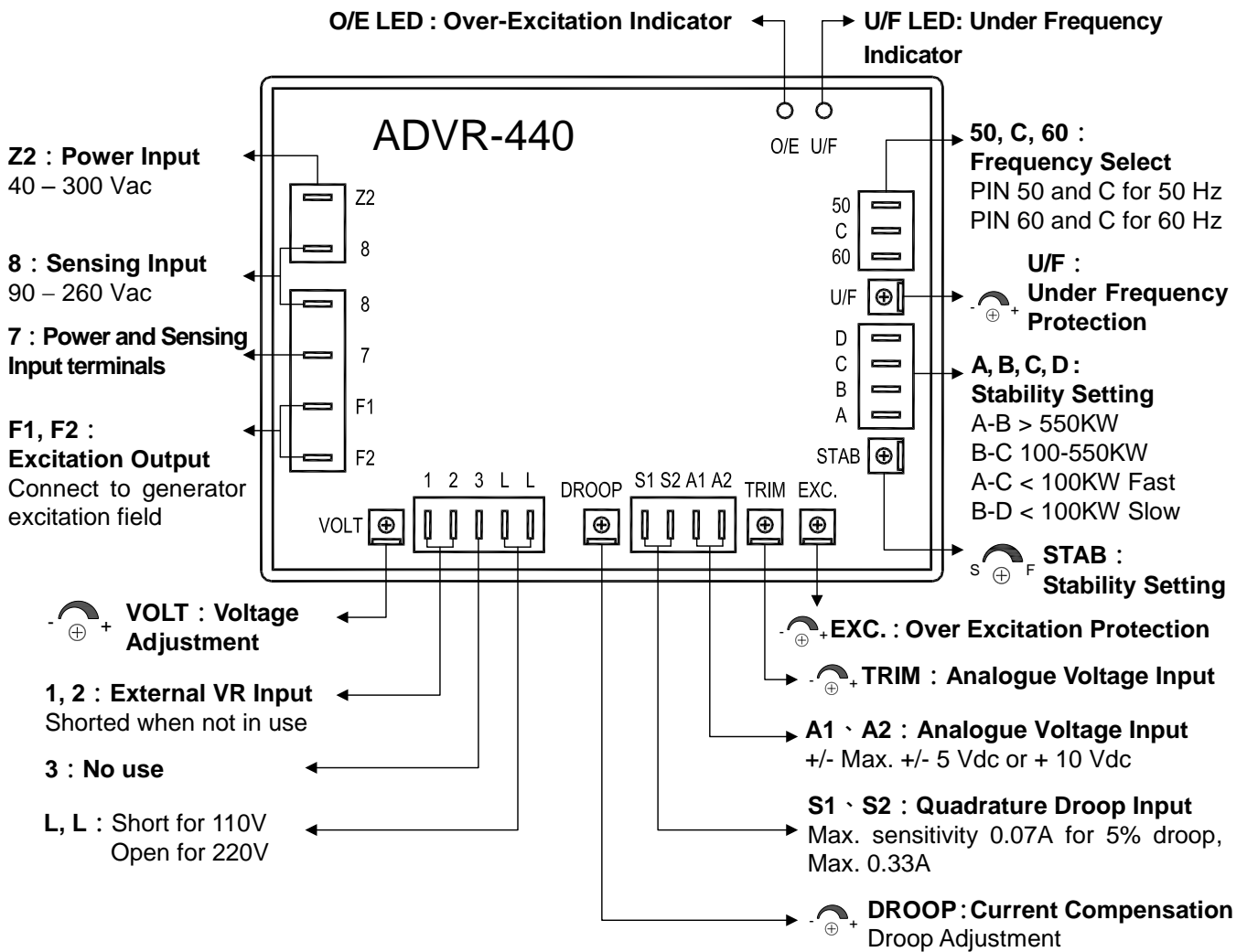

Figure 1 Outline Drawing Unit : mm [inch]

## SECTION 3 : POTENTIOMETER ADJUSTMENT



**SECTION 4 : CONNECTION DIAGRAMS**

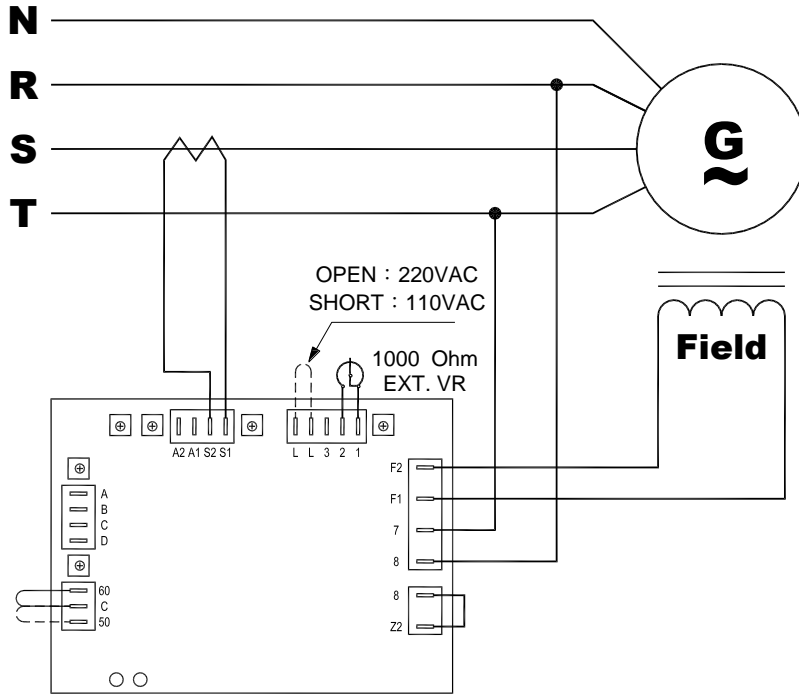

Figure 3 110/220 Vac

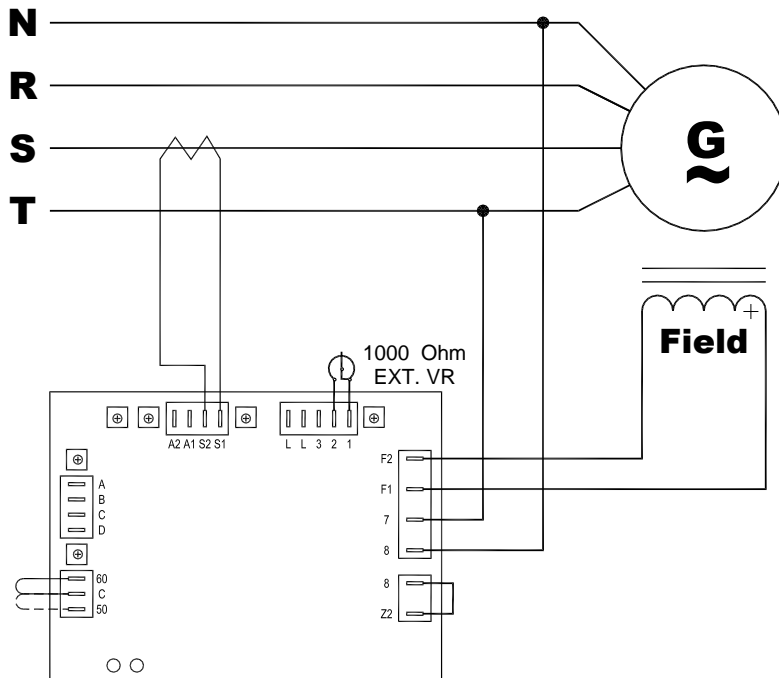

Figure 4 380/440 Vac

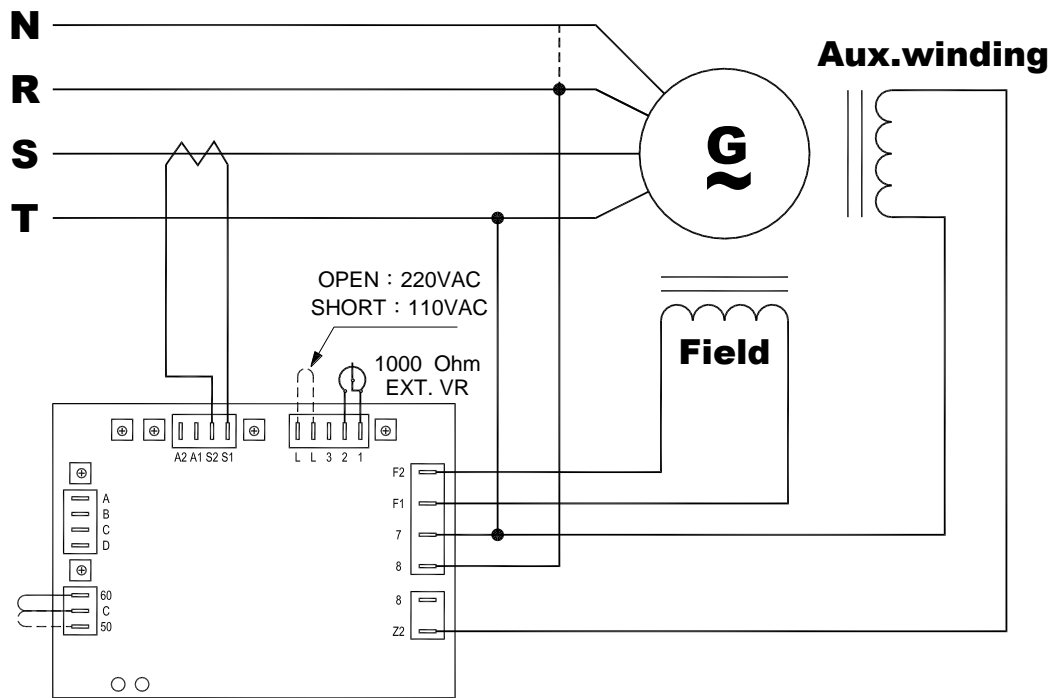

Figure 5 Auxiliary Winding

#### ATTENTION

1. All voltage readings are to be taken with an average-reading voltmeter Meggers and high-potential test equipment must not be used. Use of such equipment could damage the AVR.
2. Improper setting of under-frequency protection could cause the output voltage of the unit to drop or become unstable under with changes in load. Avoid making any changes to the U/F setting unless necessary.

- ※ Use only the replacement fuses specified in this user manual.
- ※ Appearance and specifications of products are subject to change for improvement without prior notice.