

ADVR-250

Generator Automatic Voltage Regulator Operation Manual

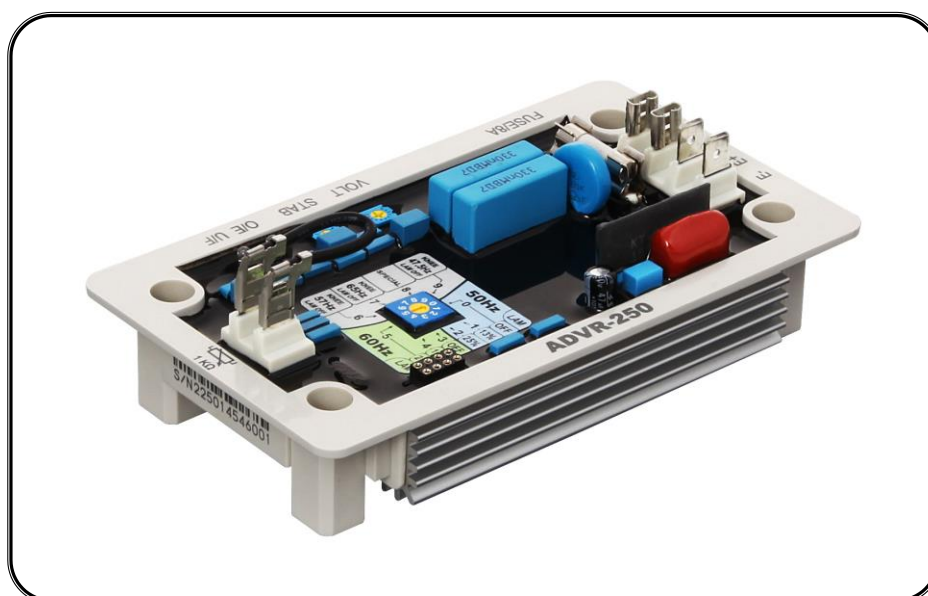

Analog / Digital › Single-phase detection › Excitation Current 3.5 Amps.

For use in brushless, self-excited (shunt) generators

Compatible with Leroy Somer* R250/R230, AVR

* Notice : Use for reference purpose only and do not imply that any part listed above is the product of the manufacturer.



SP POWERWORLD LTD
Willows, Waterside, Ryhall, Stamford, Lincs, PE9 4EY, UK
Tel: +44 1780 756872 - Email: info@sp-powerworld.com
www.sp-powerworld.com

ISO 9001
ETC

SECTION 1 : SPECIFICATION

Sensing Input (0V, 110V) Average Reading

Voltage 85 – 140 Vac, 1 phase 2 wire
 Frequency 50/60 Hz, DIP switch setting

Excitation Output (E+, E-)

120V 1 phase Continuous 63 Vdc 3.5A
 Max. 110 Vdc 5A for 10 secs
 Resistance Min. 18 ohms, Max.100 ohms
 Fuse Spec. Slow blow 5 x 20mm 8A

External Voltage Adjustment (1K ohm)

Max.+/- 14% @ 1 K ohm 1 watt potentiometer

Voltage Regulation

Less than +/- 0.5% (with 4% engine governing)

Build Up Voltage

5 Vac 25 Hz residual volts at power input terminal

Soft start ramp time

3 secnds +/- 10%

Response Time

Less than 20 milliseconds

EMI Suppression

Internal electromagnetic interference filtering

Static Power Dissipation

Max. 4 watts

Under Frequency Protection (Factory Presets)

50 Hz system knee point at 48 Hz
 60 Hz system knee point at 58 Hz

Limit Excitation current protection

Excitation Current 5 A +/- 10 %

Voltage Thermal Drift

Less than 3% at temperature range -40 to +70 °C

Under Frequency Knee Point Thermal Drift

Less than +/- 0.1 Hz at -40 to +70 °C

Environment

Operation Temperature -40 to +70 °C
 Storage Temperature -40 to +85 °C
 Relative Humidity Max. 95%
 Vibration 5.5 Gs @ 60 Hz

Dimensions

140.0 (L) x 81.0 (W) x 46.0 (H) mm
 5.51 (L) x 3.19 (W) x 1.81 (H) inch

Weight

300 g +/- 2%
 0.66 lb +/- 2%

SECTION 2 : APPEARANCE / DIMENSIONS / INSTALLATION DRAWING

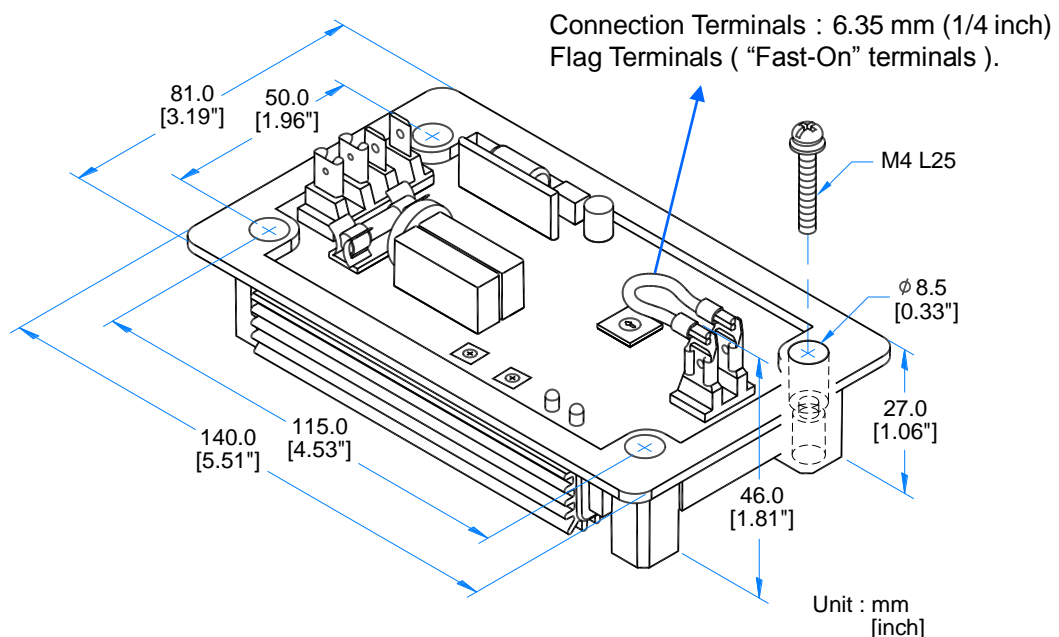
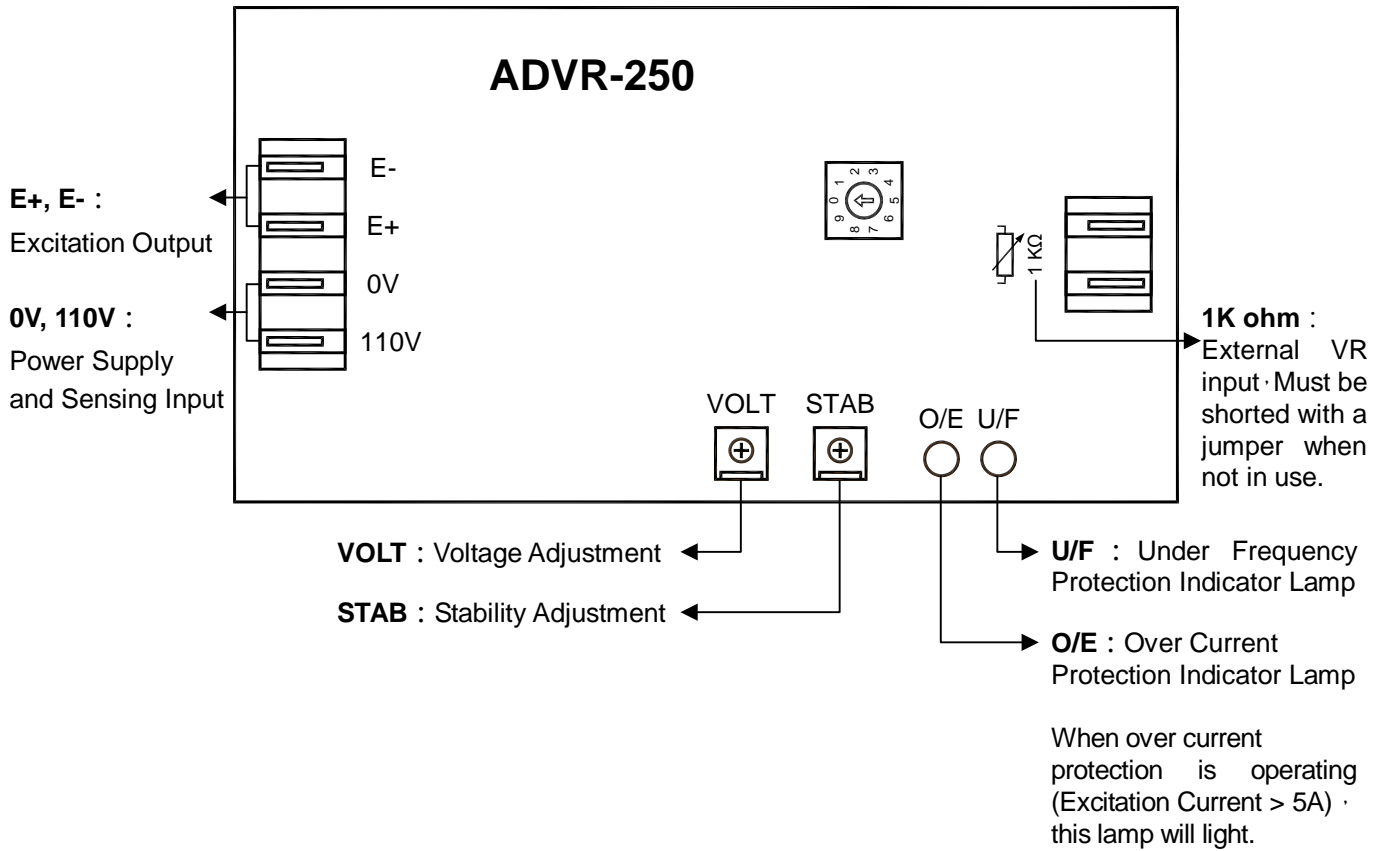

Figure 1 Outline Drawing

SECTION 3 : POTENTIOMETER ADJUSTMENT



Under Frequency Protection Selection Switch :

*** Over Current Protection Function (O/E)**

When the excitation current is greater than or exceeds 5A the AVR will reduce the excitation output to limit the excitation current. At this time the generator output voltage will be in a very unstable state (the greater the load the lower the voltage). Over current protection will not interrupt the excitation field output.

*** LAM (Load Acceptance Module) Outline**

When the generator experiences momentary increases in load (more 40% of generator capacity) voltage and engine speed will decrease. The process of recovering voltage and engine speed will produce a situation where output voltage and engine speed fluctuates. In order to reduce the level of volatility, after a load is added the engine speed will slow, lowering the total power output of the generator and delaying recovery.

The low frequency knee point setting should be below a nominal setting for 2 Hz to cause the output voltage and engine speed to have a smooth recovery.

The LAM function allows choice of reduction settings of 13% and 25%. If the generator has a fluid drive (hydro) it is recommended not to use the LAM function.

SECTION 4 : U/F PROTECTION & LAM FUNCTION SELECTION

The U/F Protection function and LAM function are selected by a switch setting.

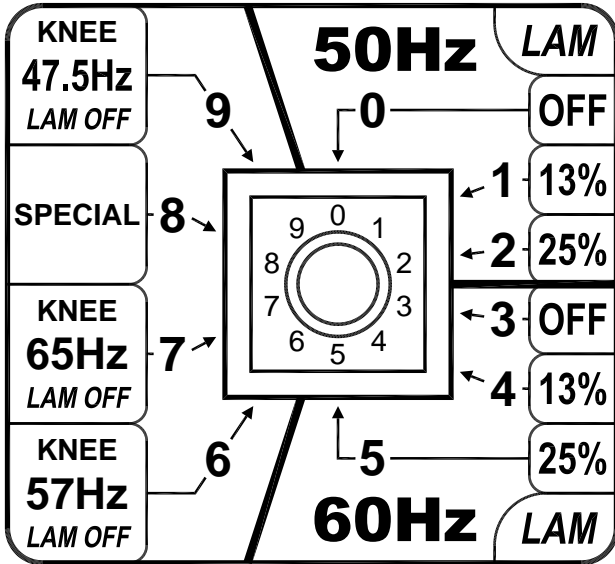

Figure 3

Warning

The switch setting must correspond to the rated frequency. An error in settings could cause damage to the generator.

50 Hz Systems

- 0 : Under Frequency knee point 48 Hz, LAM function "OFF". Use when transient loads are below 40% of rated generator capacity.
- 1 : Under Frequency knee point 48 Hz, LAM function set to (13%), Use when transient loads are between 40 – 70% of rated generator capacity.
- 2 : Under Frequency knee point 48 Hz, LAM function set to (25%). Use when transient loads are greater than 70% of rated generator capacity.

60 Hz Systems

- 3 : Under Frequency knee point 58 Hz, LAM function "OFF". Use when transient loads are below 40% of rated generator capacity.
- 4 : Under Frequency knee point 58 Hz, LAM function set to (13%), Use when transient loads are between 40 – 70% of rated generator capacity.
- 5 : Under Frequency knee point 58 Hz, LAM function set to (25%). Use when transient loads are greater than 70% of rated generator capacity.

Special Systems

- 6 : Under frequency knee point 57 Hz, LAM function "OFF". Under a load, engine speed variations can be greater than 2 Hz.
- 7 : Under frequency knee point 65 Hz, LAM function "OFF".
- 8 : Factory setting of the Under Frequency knee point is 48 Hz and LAM function "OFF". This option is supplied for special projects, which must be ordered separately and are set at the factory.
- 9 : Under frequency knee point 47.5 Hz · LAM function "OFF". Under a load, engine speed variations can be greater than 2 Hz.

SECTION 5 : CONNECTION DIAGRAMS

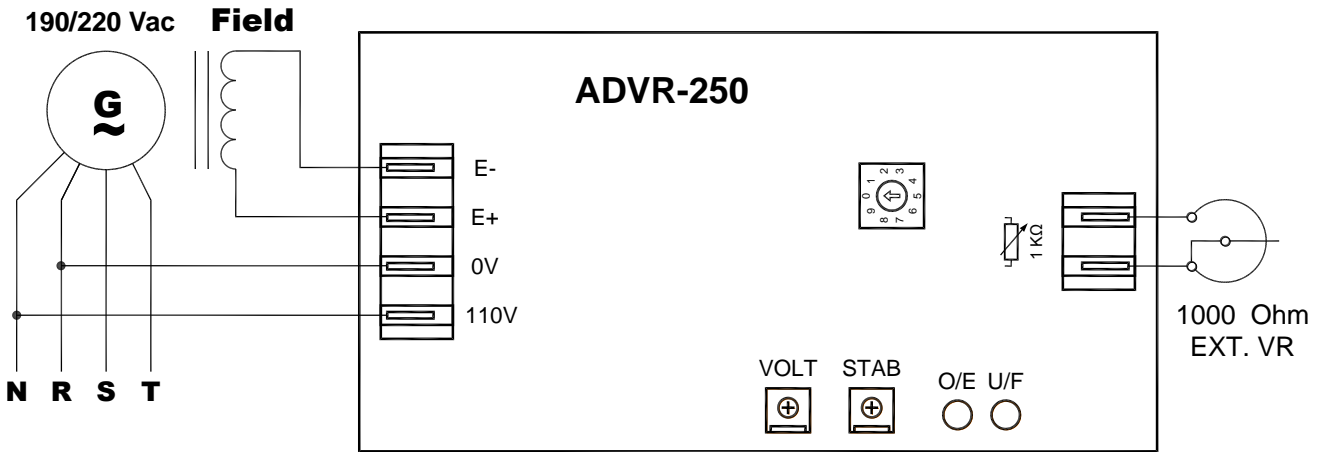

Figure 4

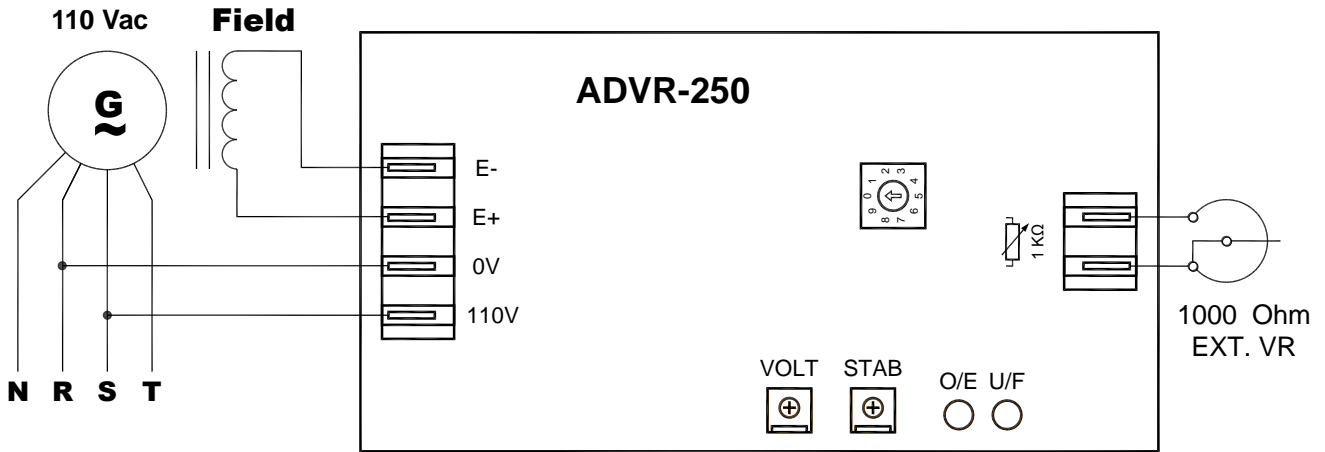

Figure 5

Warning

Before using a Megger or a Withstand Voltage Tester, removes the wires connecting to the AVR to prevent high voltage damage to the regulator.

- ※ Use only original supplied spare protection fuses as replacements.
- ※ Appearance and specifications of products are subject to change for improvement without prior notice.