

# GCU-10

## *Automatic Engine Control Unit Operators Manual*



**固也泰電子工業有限公司**  
**KUTAI ELECTRONICS INDUSTRY CO., LTD.**



**Headquarters** : No.3, Lane 201, Chien Fu ST., Chyan Jenn Dist., Kaohsiung, TAIWAN

**Tel** : + 886-7-8121771

**Fax** : + 886-7-8121775

**URL** : <http://www.kutai.com.tw>

## **TABLE OF CONTENTS**

<i>Section</i>	<i>Page</i>
<b>INTRODUCTION</b> .....	3
<b>1. PANEL LAYOUT</b> .....	3
1.1 FRONT PANEL LAYOUT.....	3
1.2 REAR PANEL LAYOUT .....	3
<b>2. OPERATION</b> .....	4
2.1 MANUAL OPERATION.....	4
2.2 AUTO (REMOTE START) OPERATION .....	4
2.3 OFF OPERATION.....	4
<b>3. PROTECTION SETTING AND SYSTEM WARNING FAILURE DESCRIPTION</b> .....	5
3.1 PROTECTION SETTING .....	5
3.2 ICON REFERENCE TABLE .....	5
<b>4. SYSTEM INSTALLATION</b> .....	6
4.1 SPECIFICATION.....	6
4.2 WORKING ENVIRONMENT .....	6
4.3 PANEL CUT-OUT .....	6
4.4 UNIT DIMENSIONS .....	6
4.5 CONNECTION DETAILS.....	7
4.6 STANDARD WIRING DIAGRAM ( GCU-10 WITHOUT GCU-10R).....	8
4.7 STANDARD WIRING DIAGRAM ( GCU-10 WITH GCU-10R) .....	9
<b>5. TROUBLE SHOOTING</b> .....	10

## INTRODUCTION

The Model GCU-10 is an Automatic Engine Control Module, designed to meet the demand of the generator industry. The module starts and stops the generator, and fault conditions, If it senses a fault it will automatically shuts down the engine and indicates the engine failure by means of eight LED's. The technician can program the module according to different generator requirements complying with different conditions and protections.

## 1. PANEL LAYOUT

### 1.1 Front Panel Layout



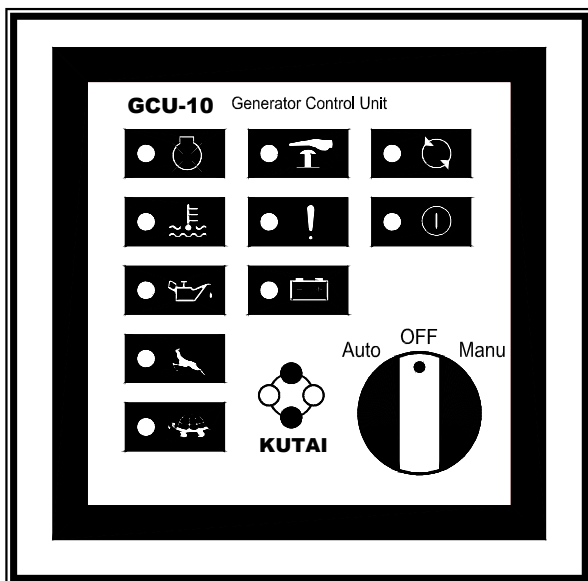

Operation of the GCU-10 is by a three position waterproof switch, indicating AUTO, OFF, and MANUAL.

Two LED's indicate POWER ON and ENGINE RUNNING and the other eight LED's indicate the operational status and fault conditions of the genset. Each LED indicates; engine start failure, high water temperature, low oil pressure, over speed, under speed, emergency stop, and low battery voltage. An extra LED and corresponding input can be defined by the technician as a failure; each LED has a picture-graph that are universally recognized.



### 1.2 Rear Panel Layout

In the back, the GCU-10 has two terminal blocks J1 & J2; five adjustment pots that change the time delay functions and five pins dip switch that set the specification of the genset.

-  A--Engine Pre-Heat  
Adjustable from 2 to 30sec
-  B--Engine Start  
Adjustable from 1 to 15sec
-  C--Engine Stop  
Adjustable from 1 to 30sec
-  D--Engine Idle  
Adjustable from 0 to 300sec. Set to 0 for no Idle.
-  E--Engine Cool down  
Adjustable from 0 to 300sec. Set to 0 for no Cool down

SW 1 - Generator Frequency

- ON - 50Hz
- OFF - 60Hz

SW 2 - Battery Voltage

- ON - 12 Volt operation
- OFF - 24 Volt operation

SW 3 - Stop Solenoid

- ON - Energize to Start
- OFF - Energize to Stop

SW 4 - Oil Pressure Switch

- ON - Normal Open NO
- OFF - Normal Close NC

SW 5 - Oil Pressure Switch (Crank Disconnect)

- ON - Not used for crank disconnect
- OFF - Used for crank disconnect

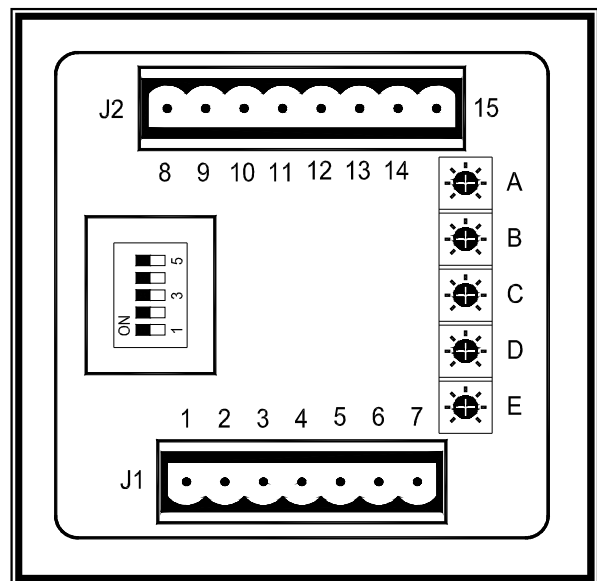

## 2. OPERATION

### 2.1 Manual Operation

To initiate a start sequence moves the front control to MANUAL.

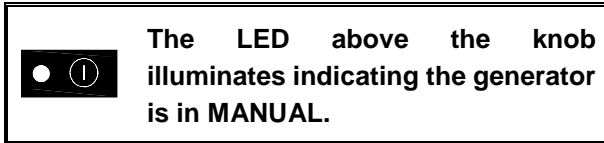

First the pre-heat timer begins by energizing terminal 4. Don't care the terminal 4 output if the pre-heat function is no used.

After pre-heat ends, the module de-energizes terminal 4 and begin engine starting.

The module Fuel Solenoid energizes terminal 10, together with Engine Idle terminals 14 & 15.

After a 1 sec. delay, the starter motor engages, and the engine cranks for the duration of the crank timer.

When the engine fires, the starter motor is disengaged and locked out with an 18-Hertz signal from the generator output. Alternatively, the oil pressure switch can serve as an additional back up crank release.

When the engine fires and the Engine Idle option is used, the ENGINE RUNNING LED will continuous flashing in Idle period indicating the status is IDLE.

Should the engine not fire on the first attempt and the crank timer expires the module will once again attempt to start the engine until the engine fires or after the third attempt is completed.

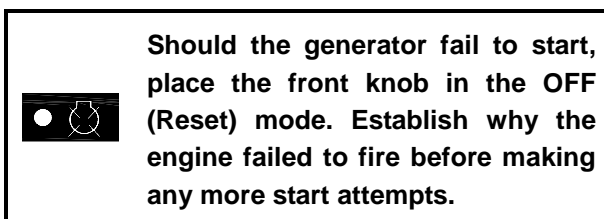

After the generator starts, the module allows Oil Pressure, High Engine Temperature, Under speed, and the Auxiliary fault input to stabilize without triggering any faults in 20 seconds. Once the engine is running full fault protection is available.

By moving the knob to the OFF position, the genset will STOP immediately.

### 2.2 Automatic (Remote Mode) Operation

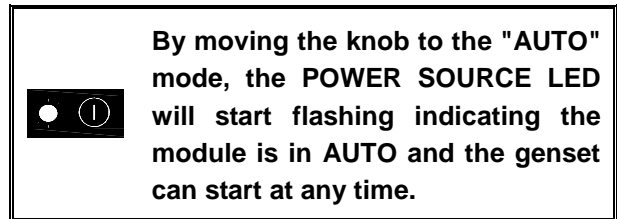

In the "AUTO" position, the module monitors input terminal 9 for a "REMOTE START" signal. Should a "REMOTE START" signal be detected a start sequence similar to previous manual start sequence is initiated.

When removes the Remote Start signal the Cool Down delay timer will count down. After the Cool Down ends, the Fuel Solenoid is ( de-energized or energized as the case may be ) bringing the generator to a stop and the POWER SOURCE LED will start flashing, indicating the genset is on standby and ready to start.

Should the Remote start signal be re-activated during the cooling down period, the set will immediately return to load.

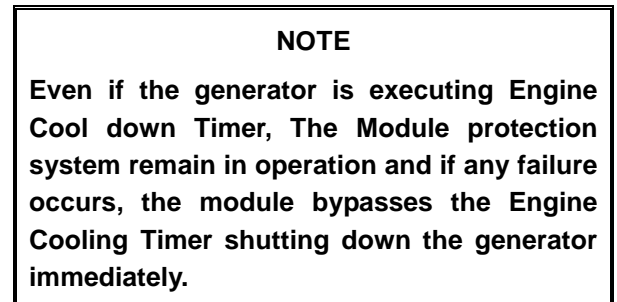

### 2.3 OFF Operation

The OFF position places the module into its Stop or Reset mode. This will clear any alarm conditions for which the triggering criteria have been removed.

If the engine is running and this position is selected, the module will automatically shut down the generator. The fuel supply will be removed and engine will be brought to a standstill. Should a remote start signal be present while operating in this mode, a remote start will not occur.

### 3. PROTECTION SETTING AND SYSTEM WARINNG FAILURE DESCRIPTION

#### 3.1 Protection Functions

##### Engine fail to start reattempt

Engine tries 3 times to start

##### Engine High Water temperature Protection

Shutdown activated after 3 seconds  
Temperature Switch Type "Normally Open"

##### Engine Low Oil Pressure Protection

Shutdown activated after 3 seconds  
Oil Pressure Switch Type  
Normal Open or Normal Close

##### Engine Over-speed Protection

Shutdown activated after 3 seconds  
If set for 50Hz operation, Over-speed is activated at 55 Hz

If set for 60Hz operation, Over-speed is activated at 66 Hz

##### Engine Under Speed Protection

Shutdown activated after 5 seconds  
If set for 50Hz operation, Under-speed is activated at 45 Hz

If set for 60Hz operation, Under-speed is activated at 54 Hz

##### Emergency Shutdown

Shutdown activated by Normal Open Contacts

##### Spare / User define Shutdown

Activated after 5 seconds delay  
Using Normal Open Contacts

##### Low Battery Voltage Warning

Activated after 5 seconds delay  
For 12VDC operation set at 10 V  
For 24VDC operation set at 20 V

##### Start-Up Grace Period

There is 20 seconds after engine idle ends, all alarms are ignored untile start-up grace period expired except the emergency stop and over speed.

Once the engine is running full fault protection is available.

#### 3.2 Icon Reference Table

ICON	DESCRIPTION	EXECUTION
	Power Source Indication	Generator standby in Auto LED Flashing
	Generator Operating Normally	
	Engine Start Failure	Shutdown
	High Water Temperature	Shutdown
	Low Engine Oil Pressure	Shutdown
	Over-speed	Shutdown
	Under-speed	Shutdown
	Emergency Shutdown Activated	Shutdown
	Spare Shutdown	Shutdown
	Low Battery Voltage Warning	Warning Only

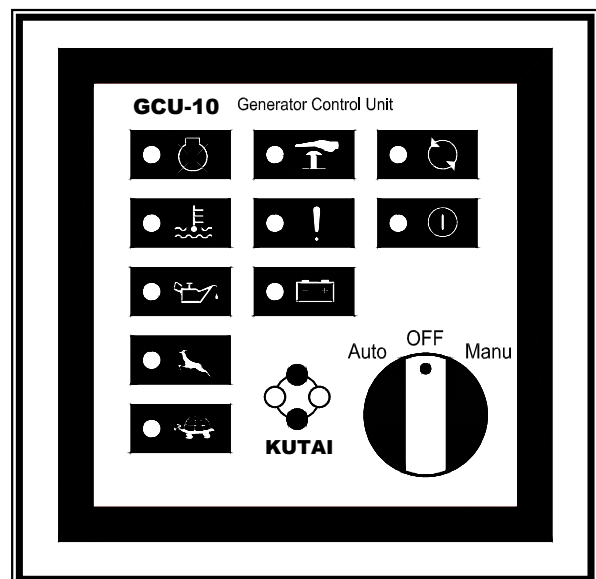

## 4. SYSTEM INSTALLATION

Install the Model GCU-10 Module on the front panel by using the two installation clips provided. When installed in a panel with too much vibration use appropriate anti-vibration isolators.

### 4.1 Specification

DESCRIPTION	SPECIFICATION
DC Supply	9.0 to 36 VDC
Alternator Input Range	5 ~ 300VAC
Alternator Input Frequency	50/60 Hz
Fuel Solenoid Signal Output	5 Amp @ 12/24VDC
Start Signal Output	5 Amp @ 12/24VDC
Warm up Signal Output	5 Amp @ 12/24VDC
Accessory "ON" Output	5 Amp @ 12/24VDC
Idle Control Conductor Capacity	5 Amp @ 12/24VDC
Operating Temperature	-20 °C to +70 °C
Relative Humidity	90% or Below
Power Consumption	Under 3W
Weight	166 g ± 2%

### 4.2 Working Environment

The module works over a wide temperature range -20 to +70° C however, make allowances for temperature rise within the control panel enclosure. Do not mount close to any heat sources without adequately ventilated; also, the humidity inside the control panel should not exceed 90%.

### 4.3 Panel CUT-OUT in mm

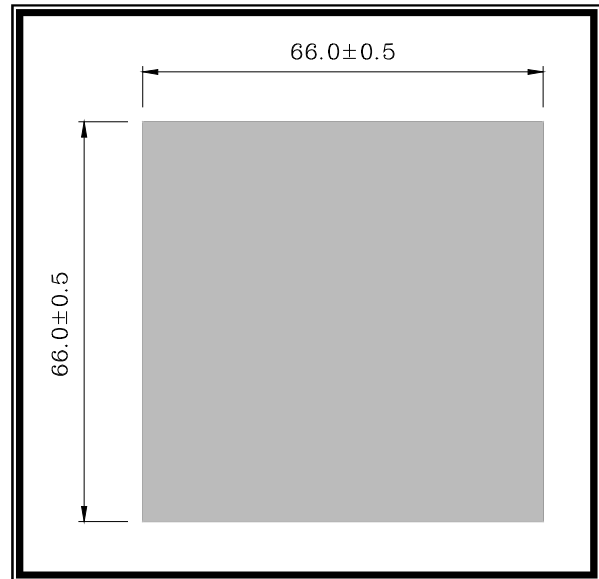

### 4.4 Unit Dimensions (Measurement : mm)

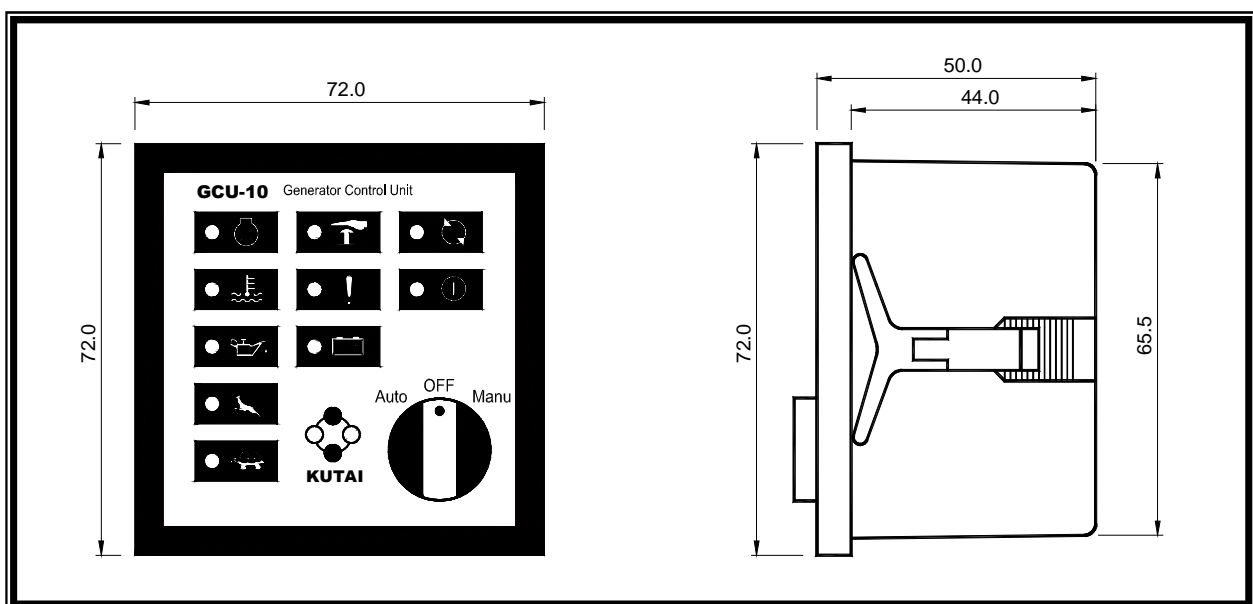

#### 4.5 Connection Details

##### Seven pins din rail terminal J1

PIN No.	DESCRIPTION	NOTES
1	Generator sensing Input	Connect to Alternator Output
2	Generator sensing Input	Connect to Alternator Output
3	Oil Pressure switch Input	Connect to Oil Pressure Switch
4	Pre-heat Signal Output	Connect to Internal heater. Supply (+V) 5 Amp rated
5	Accessory "ON" Output	Connect to illuminate panel light. Supply (+V) 5 Amp
6	DC Plant Supply Input (+V)	System DC positive input (Battery Positive)
7	DC Plant Supply Input (-V)	System DC negative input (Battery Negative)

##### Eight pins din rail terminal J2

PIN No.	DESCRIPTION	NOTES
8	Spare / User Define Warning Signal Input	Signal need to be a negative switch Input
9	Remote Start Input	Connect to A.T.S device. Signal needs to be a negative switch input
10	Fuel Solenoid Signal Output	Connect to Fuel Solenoid or Fuel Valve Control. Supply (+V) 5 Amp
11	Start Signal Output	Connect to Starter Motor. Supply (+V) 5 Amp
12	Emergency Stop Input	Connect to External Emergency Stop Switch. Signal needs to be a negative switch input
13	Coolant Temperature switch Input	Connect to Water Temperature switch. Signal needs to be a negative switch input
14	Idle Signal Output	Connect to Governor (Speed Control) Idle control Dry contacts 5 Amp rated
15	Idle Signal Output	Connect to Governor (Speed Control) Idle control Dry contacts 5 Amp rated

##### Rear Panel layout

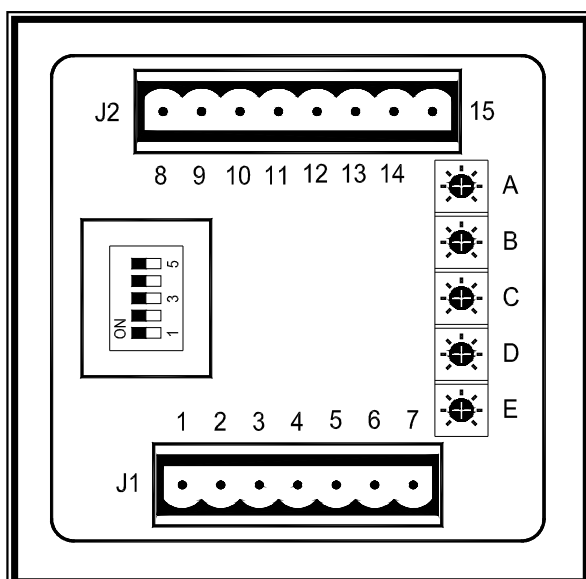

4.6 Standard Wiring Diagram ( GCU-10 Without GCU-10R )

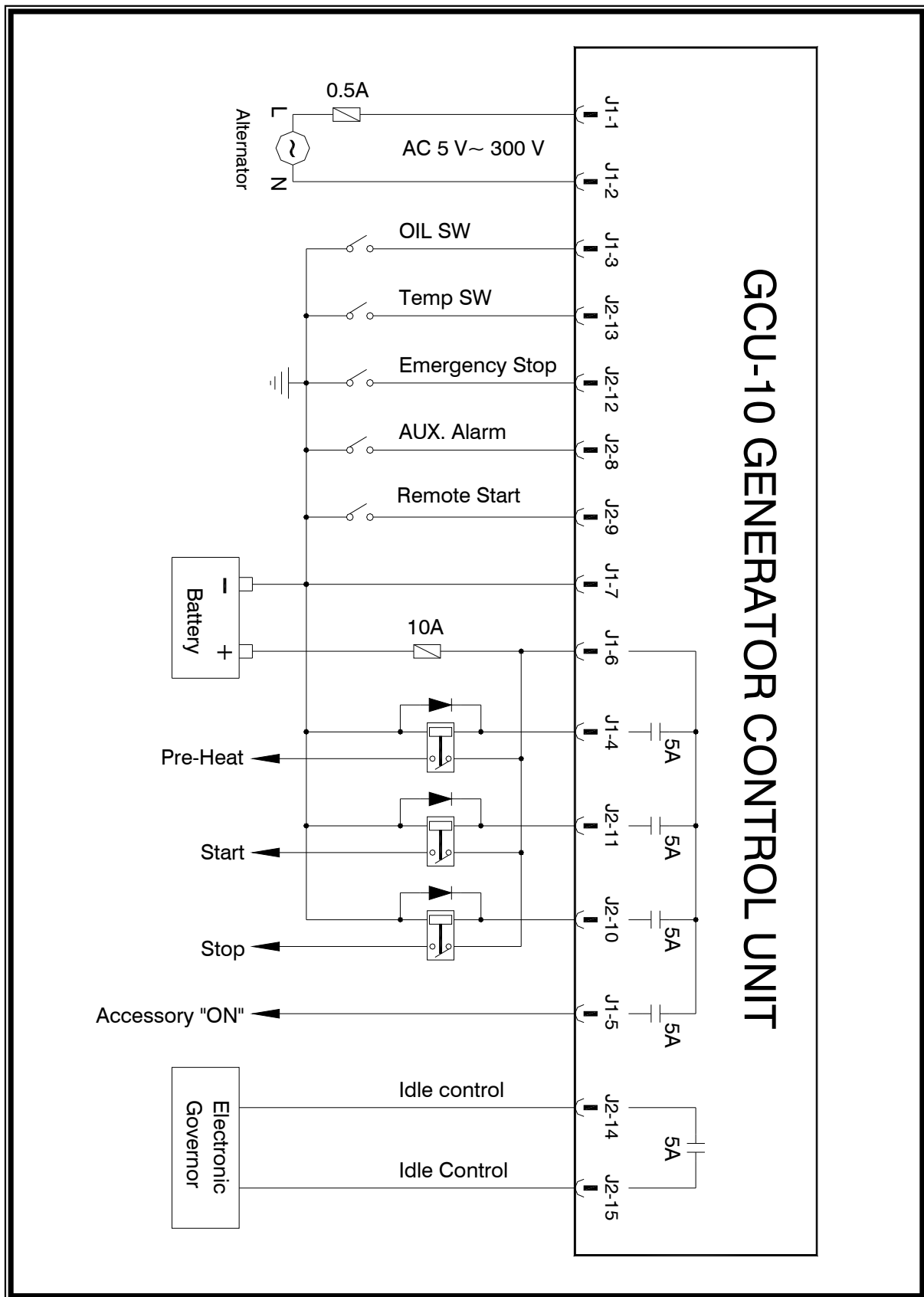



4.7 Standard Wiring Diagram ( GCU-10 With GCU-10R )

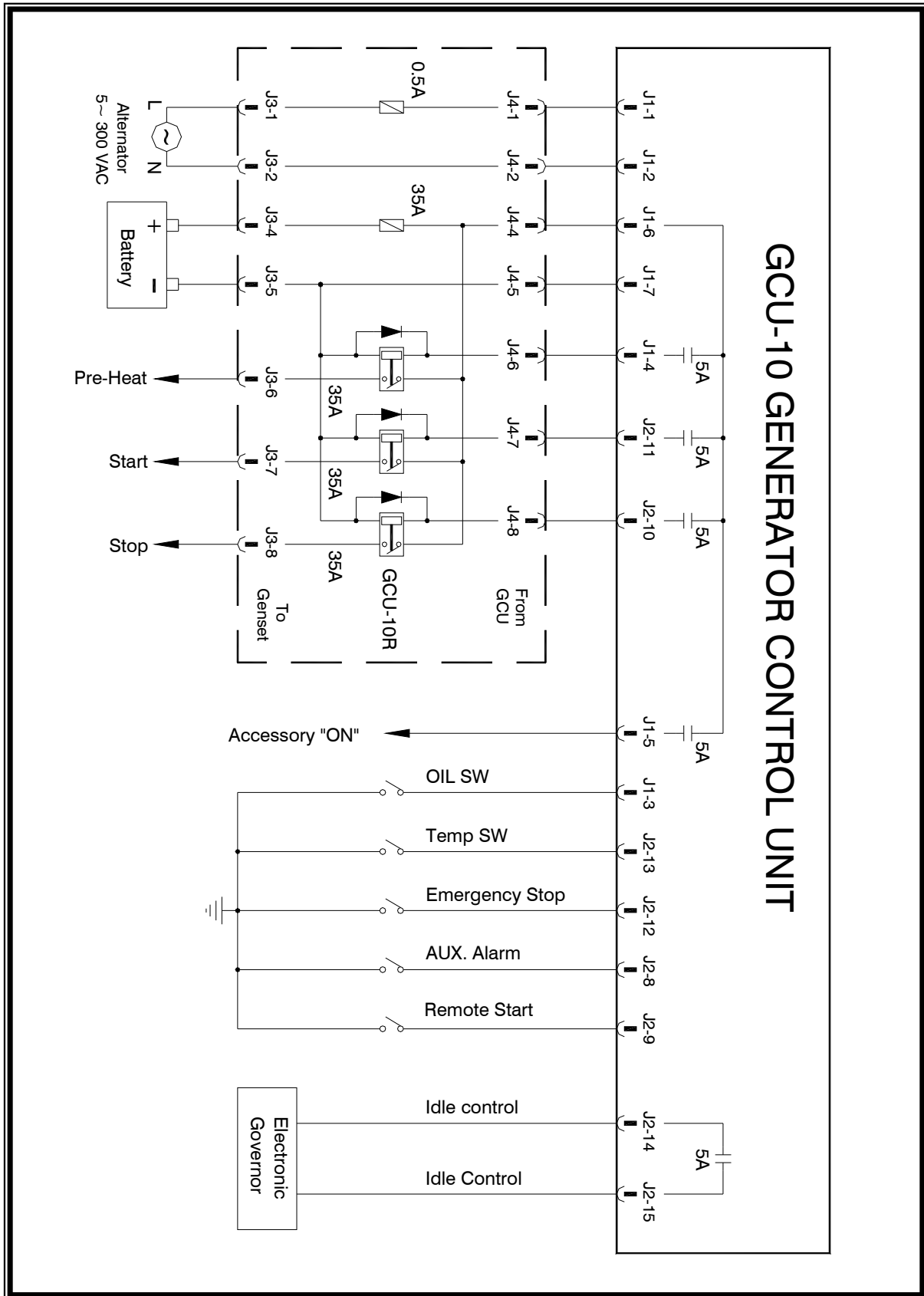

## 5. TROUBLE SHOOTING

SYMPTOM	PLEASE CHECK	REMEDY
In "MANUAL MODE" Power Source LED does not illuminate and generator can not start.	<ul style="list-style-type: none"> <li>• Check Battery Volts on cranking (Not below 6V)</li> <li>• Check DC supply Voltage</li> <li>• Check DC supply fuse</li> <li>• None of the above</li> </ul>	<ul style="list-style-type: none"> <li>• Change Battery</li> <li>• Check and confirm voltage and wiring</li> <li>• Change fuse</li> <li>• Change Control Unit</li> </ul>
In "MANU MODE" Power Source Indication illuminates and Starter Motor fails to operate.	<ul style="list-style-type: none"> <li>• Check Battery Volts on cranking (Not below 6V)</li> <li>• Check oil pressure switch type</li> <li>• Check GCU-10 Start signal output</li> <li>• Check Starting motor</li> <li>• Check wiring to see if it is open circuit</li> </ul>	<ul style="list-style-type: none"> <li>• Change Battery</li> <li>• Correct Oil pressure Switch type to correct setting</li> <li>• Change Control Unit</li> <li>• Change Starting motor</li> <li>• Correct the fault point</li> </ul>
In "MANUAL MODE" Power Source LED illuminates and Starter Motor ails to crank.	<ul style="list-style-type: none"> <li>• Check fuel</li> <li>• Check wiring of fuel solenoid</li> <li>• Check Governor and wiring</li> </ul>	<ul style="list-style-type: none"> <li>• Add fuel</li> <li>• Correct Engine Stop Mode setting</li> <li>• Change Governor</li> </ul>
In "MANUAL MODE" Starter Motor cranks but engine fails to fired	<ul style="list-style-type: none"> <li>• Check Battery Volts on cranking (Not below 6V)</li> <li>• Check Starting circuit and wiring</li> <li>• Check oil pressure Switch</li> </ul>	<ul style="list-style-type: none"> <li>• Change Battery</li> <li>• Change Wiring</li> <li>• Change appropriate oil pressure switch or cancel the Oil Pressure Detection Engine Start option</li> </ul>
Starting motor does not disengage after generator starts	<ul style="list-style-type: none"> <li>• Check AC Input Voltage (5~300VAC)</li> <li>• Check wiring to see if it is open circuit</li> <li>• Check oil pressure switch</li> <li>• Check Starter motor</li> </ul>	<ul style="list-style-type: none"> <li>• Change Automatic Voltage Regulator (AVR)</li> <li>• Correct the fault point</li> <li>• Change appropriate oil pressure switch</li> <li>• Change Starting Motor</li> </ul>
Emergency stop always. Engine not operating And does not start	<ul style="list-style-type: none"> <li>• Check emergency stop terminal and wiring</li> <li>• Check wiring to see if it is short circuit</li> </ul>	<ul style="list-style-type: none"> <li>• Select emergency stop to normal open input</li> <li>• Correct the wiring</li> </ul>
Low oil pressure always while engine is running	<ul style="list-style-type: none"> <li>• Check engine oil pressure</li> <li>• Check oil pressure switch</li> <li>• Check wiring to see if it is open circuit</li> </ul>	<ul style="list-style-type: none"> <li>• Add engine oil / lubricant</li> <li>• Change oil pressure switch</li> <li>• Correct the fault point</li> </ul>
High water Temp always while engine is running	<ul style="list-style-type: none"> <li>• Check engine temperature</li> <li>• Check water temperature switch</li> <li>• Check wiring for short circuit</li> </ul>	<ul style="list-style-type: none"> <li>• Change water temperature switch</li> <li>• Correct the fault point</li> </ul>

SYMPTOM	PLEASE CHECK	REMEDY
In "Auto Mode" the generator does not start with a remote start signal	<ul style="list-style-type: none"> <li>• Check Engine Pre-heat countdown Setting to see if preset time (2 ~ 30 sec) has been reached</li> <li>• Check remote start signal input</li> <li>• Check GCU-10 start signal output</li> </ul>	<ul style="list-style-type: none"> <li>• Correct the fault point</li> <li>• Change Control Unit</li> </ul>
Pre-heat does not work	<ul style="list-style-type: none"> <li>• Check wiring to see if it is open circuit</li> <li>• Check Engine Pre-heat Countdown Setting</li> <li>• Check GCU-10 Pre-heat signal output</li> </ul>	<ul style="list-style-type: none"> <li>• Correct the fault point</li> <li>• Reset settings</li> <li>• Change Control Unit</li> </ul>
Engine does not be stopped in off mode	<ul style="list-style-type: none"> <li>• Check Engine Cooling Countdown time setting (excessive time delayed)</li> <li>• Check Engine Stop Countdown time setting (inadequate time delayed)</li> <li>• Check Engine Stop Mode setting</li> <li>• Check GCU-10 Engine Shutdown output signal</li> <li>• Check Fuel Solenoid</li> </ul>	<ul style="list-style-type: none"> <li>• Reset Engine Cooling Countdown time</li> <li>• Reset Engine Stop Countdown time</li> <li>• Reset Engine Stop Mode Change Control Unit</li> <li>• Change Fuel Solenoid</li> </ul>